



# Power Protector Stabilizer

## PPS MFS-Lw - Instruction Manual-



**PPS MFS-Lw** is an incorporated **Power Protector Stabilizer** that stabilizes the voltage and supervises the voltage, frequency, ambient temperature, and current in order to ensure the safe operation of **commercial refrigeration appliances** (*appliances falling into EN/IEC 60335-2-89 scope*). The product is a split type and consists of the **ECU (Electronic Control Unit)** and the **Trafo** (Autotransformer).

**PRODUCT FEATURES:**

- Voltage stabilizer
- Voltage, Frequency, and Current supervisor
- Intelligent ambient temperature protection
- Intelligent Time delay 4'30"+0"to30" random
- Surge protection
- Reconnecting Voltage Hysteresis
- Zero-Crossing
- Soft Start
- Zero current change over

**Electronic Control Unit - ECU& Trafo**

- (1): "OUT OF LIMITS" led ( Red )                      (3), (6): Mounting points  
 (2): "OPERATION" led ( Green )                      (4): Fast on terminals  
 (5): Connection cables - Fast On female terminal

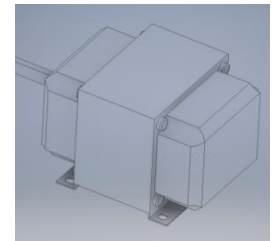
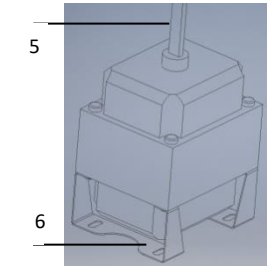
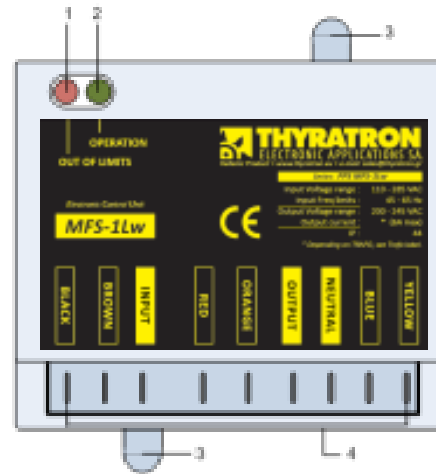

## LED INDICATION

EVENT	OUT OF LIMITS led (RED)	OPERATION led(Green)
Normal operation	Off	On
4 minutes delay	Blink slow	Off
Frequency out of limits	Blink fast	Off
Temperature out of limits	Blink slow	Blink slow
PPS MFS Failure or No Power	Off	Off

## VOLTAGE STABILIZATION

OUTPUT VOLTAGE limits	
PPS MFS-Lw performs voltage correction and stabilization using Autotransformer, Relays and Triac.PPS MFS-Lw makes switching in order to keep the output voltage within limits.	200 - 245 VAC±2%

## VOLTAGE & FREQUENCY MONITORING

INPUT VOLTAGE limits		INPUT FREQUENCY limits		
PPS MFS-Lw monitors voltage and frequency of main power and cuts off the output when the values of main power (voltage or frequency) come out of limits.	110 - 285VAC ±2%	Stage \ Hz	50 Hz	60 Hz
		Stage_1: Continuously Operation	47-53	57-63
		Stage_2: 60mins Delay to Cut-Off	46-47 & 53-54	56-57 & 63-64
		Stage_3: 10mins Delay to Cut-Off	45-46 & 54-55	55-56 & 64-65
		Stage_4: Instant Cut-Off	< 45 & > 55	< 55 & > 65

## SPECIFICATIONS

PPS MFS-Lw Series :				PPS MFS-1Lw					PPS MFS-2Lw	
PPS MFS-xxxLwSeries (xxx: 070, 085, 100, 150, 200)				040	060	070	085	100	150	200
Power Supply	Nominal Voltage			220 - 240 VAC						
	Operation Voltage Bandwidth (@ 25°C)			60 - 415 VAC						
	Ambient Temperature		Humidity		-5 to +45 °C			5 - 95 %RH, non-condensin		
Input	Voltage	Low	High	110 VAC ± 3% with hysteresis				285 VAC ±2% with hysteresis		
	Frequency Lower / Upper	50Hz	60Hz	45 / 55 Hz ±0.2Hz				55 / 65 Hz ±0.2Hz		
Output	Voltage range			200 - 245 VAC ±2%						
	Continuous Operation (45°C) Current (A) @ Low Voltage							3.2		
Start-Up Time, Time Delay				- 5 minutes ( 4'30" + 0" to 30" random) - Zero on Production Line for first 30 minutes continuous operation of life cycle						
Output current protection				Circuit Breaker Type C						
Thermal protection				- Temperature limits +80 °C - Temperature rise 15°C / 15 minutes						
Plastic Housing				UL94 V-0 Flame Retardant						
IP Class				IP44						
Lifetime				Relay lifetime cycles 350,000						
Connections				6.3mm x 0.8mm flat, terminal						
Cable Harness - Lengths				250mm / 550mm / 1000mm versions						
Insulation Class, Transformer Windings				H ( 180°C)						
Dimension (mm)	ECU			114 x 98 x 31						
	Trafo	- Standard installation - Vertical installation						130x95x110 108x140x90		
Total weight (Kg)								4.3		

## SAFETY INSTRUCTIONS - INSTALLATION

---

### What this chapter contains

This chapter contains the safety instructions you must follow when installing, operating, and servicing the **Power Protector Stabilizer MFS**. If ignored, physical injury or death may follow and/or damage may occur to the **PPS MFS**. Read the safety instructions before you work on the unit. These warnings are intended for all who work on the PPS MFS, or cable.

---



**WARNING!** Only a qualified electrician may carry out the work described in this chapter. Ignoring the safety instructions can cause physical injury, death or/and damage to the equipment. Make sure that the device is disconnected from the mains (input power) during installation.



Beware of hot surfaces. Some parts, such as a transformer, may remain hot for a while after disconnecting the electrical supply.

- Only qualified personnel are allowed to install and maintain the PPS MFS.
- PPS MFS is intended to be built into commercial refrigeration appliances or other enclosures that provide protection against certain external influences and, in any direction, protection against direct contact and electric shock.
- It shall be installed in an area where it is inaccessible without disassembly of the enclosing area.
- Never work on the PPS MFS or cable when main power is applied. Always ensure by measuring with a multimeter (impedance at least 1 Mohm) that voltage between device input phases INPUT and NEUTRAL is close to 0V. Externally supplied control circuits may cause dangerous voltages inside the device even when the main power on the drive is switched off.
- Do not make any insulation or voltage withstand tests on the device.
- When reconnecting the wiring, always check that the Phase - Neutral order is correct.
- Do not change the electrical installations of the PPS MFS. Changes may affect the safety performance or operation of the device unexpectedly. All customer-made changes are on the customer's responsibility.
- Make sure that dust from borings and grindings does not enter the drive when installing. Electrically conductive dust inside the unit may cause damage or malfunctioning.
- Do not fasten the device by welding.

**Note:** Traces of rust on sharp edges and any yellowish film (removable by rubbing) that may appear on outer surfaces of the autotransformers iron cores due to certain conditions (marine environments, high humidity, rain, snow, wind, dust, pollution, ultraviolet rays, and sea salt), have no effect in high reliability performance and lifetime of the product.

The fast-on terminals on the device are at a dangerously high voltage when the input power is on.

## INSTALLATION AND MAINTENANCE WORK

- The PPS MFS consists of two parts, the Electronic Control Unit (ECU) and the Autotransformer (Trafo). The ECU and the Trafo of the device are delivered in a separate cardboard box. The type, size, and material of the package depend on the frame size of the Autotransformer.
- The parts of the PPS MFS must be connected by using fast-on terminals taking in care the coloring code of the cables and ECU.
- PPS MFS is intended to be used with the protection of a fuse gG, type B, IEC60269-3-1.
- Confirm compatibility with connection terminals as well as insulation. The connectors are Fast On terminals 6.3x0.8mm
- The device must be installed in an upright position (see figure on the right) with allowance for adequate cooling.

IP rating is met only when the ECU is installed vertically with the connection tabs at the bottom. This is also important as the ECU also detects ambient temperature as one of its features.

- At the output of the device must be connect a MCB type C in order to protect from overcurrent or short circuit (*indicative type: Schneider Acti 9 iC60 A9F84103*).
- An earth-ground connection must take place on to the Trafo. Detail of grounding Transformer Enclosure during implementation in the appliance. (IEC 60417-5019)

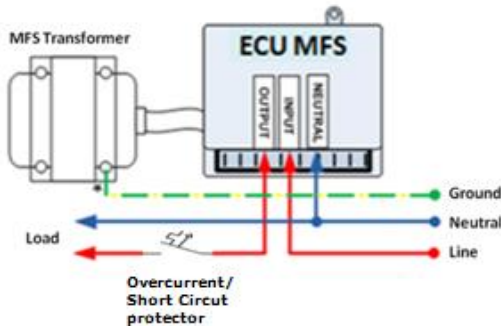
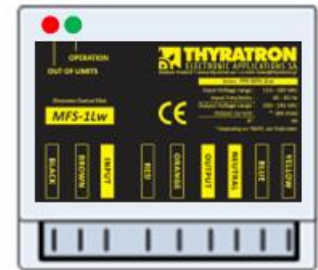
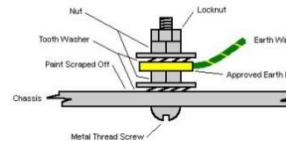

### Before powering the device:

- Confirm color coding between ECU and Autotransformer
- Confirm the correct fitting of the terminals to ensure IP rating of the connections.

## MAINTENANCE, DIAGNOSTIC AND REPAIR PROCEDURES

The PPS MFS maintenance-free and is made up of non-repairable / refurbishable parts. In the event of a failure of the PPS MFS, both ECU and Trafo have to be replaced with new, unused units. Part replacement is not advisable.

In order to reset the voltage stabilizer, cut off the main power and reconnect\* after 15 seconds (power cycle). The output voltage is reconnected automatically with time delay.

\*Warning: Reconnection of the main power, must be done after the checking of the overcurrent protector. If it has been activated, first the overload or short circuit condition must be resolved and then the overcurrent protector can be reset.

## STORAGE

Should not be stored and/or transport in high temperature or high humidity condition. Usage, beyond the specified shelf life could compromise product long term reliability. The suitable condition is +5 to +35°C and less than 95% RH in Relative Humidity indoor. Applicable ambient temperature and humidity range during transport and storage: -30 to +70°C, 5 to 95% RH.

## GUARANTEE & RETURNS

Thyratron S.A. provides a guarantee of 2 years from the date of purchase of this product. Please refer to file “PP4-1.ef10\_General Conditions of Sale” for full warranty terms and conditions.

## END-OF-LIFE RESOURCE RECOVERY AND RECYCLING PROCEDURES.

Disposal of Old Electrical & Electronic Equipment (Applicable in the European Union and other European countries with separate collection systems).



This symbol on the product or on its packaging indicates that this product shall not be treated as household waste when disposed of. Instead, it shall be handed over to the applicable collection point for the recycling of electrical and electronic equipment. By ensuring this product is disposed of correctly, you will help prevent potential negative consequences for the environment and human health, which could otherwise be caused by inappropriate waste handling of this product.

Please ensure your product(s) is/are disposed of by a registered WEEE waste carrier.

**FURTHER INFORMATION**

Support: [rnd@thyratron.gr](mailto:rnd@thyratron.gr)      Sales: [sales@thyratron.gr](mailto:sales@thyratron.gr)

Site: [www.thyratron.gr](http://www.thyratron.gr)      Follow us at [linked in](#), [Facebook](#)

Address: Kydonies Vasiliko, Erymanthos, Achaia, GR25008, GREECE

Tel: +30 26940 61868      Fax: +30 26940 62001