



Power Protector Stabilizer

WAVE Series

- Installation Guide -

The following document applies to PPS WAVE

1. Safety instructions

What this chapter contains

This chapter contains the safety instructions which you must follow when installing, operating and servicing the **Power Protector Stabilizer WAVE**. If ignored, physical injury or death may follow, or damage may occur to the **PPS WAVE**. Read the safety instructions before you work on the unit.

Use of warnings and notes

There are two types of safety instructions throughout this manual: warnings and notes. Warnings caution you about conditions which can result in serious injury or death and/or damage to the equipment. They also instruct you how to avoid the danger. Notes draw attention to a particular condition or fact, or give information on a subject. The warning symbols are used as follows:



Dangerous voltage warning warns of high voltage which can cause physical injury and/or damage to the equipment.



General warning warns about conditions, other than those caused by electricity, which can result in physical injury and/or damage to the equipment.



Electrostatic discharge warning warns of electrostatic discharge which can damage the equipment.



Hot surface warning warns of hot surfaces which can cause physical injury.

1.1. Installation and maintenance work

These warnings are intended for all who work on the PPS WAVE, or electric cables.



WARNING! Ignoring the following instructions can cause physical injury or death, or damage to the equipment:

- Only qualified personnel are allowed to install and maintain the PPS WAVE.
- PPS WAVE is intended to be built into **commercial refrigeration appliances** or other **enclosures** that provide protection against certain external influences and, in any direction, protection against direct contact and electric shock.
- Never work on the PPS WAVE or electric cables when main power is applied. Always be ensured by means of a multimeter (impedance at least 1 Mohm) that voltage between the device's input phases INPUT and NEUTRAL is close to 0V.
- Do not work on the cables when power is applied to the device or to the external control circuits. Externally supplied control circuits may arise dangerous voltages inside the device even when the main power on the drive is switched off.
- Do not make any insulation or voltage endurance tests on the device.
- When reconnecting the wiring, always check that the phase order is correct.
- Do not change the electrical installations of the PPS WAVE. Changes may affect the safety performance or operation of the device unexpectedly. All customer-made changes are on the customer's responsibility.

Note:

- Traces of rust on sharp edges and any yellowish film (removable by rubbing) that may appear on outer surfaces of the autotransformers iron cores due to certain conditions (marine environments, high humidity, rain, snow, wind, dust, pollution, ultraviolet rays, and sea salt), have no effect in high reliability performance and lifetime of the product.
- The fast-on terminals on the device have dangerously high voltage value when the input power is on.

1.2. Mechanical installation and maintenance

These instructions have to be read and understood by all personnel who take part at the installation and service procedures of the PPS WAVE.



WARNING! Ignoring the following instructions can cause physical injury or death, or damage to the equipment:

- Handle the unit carefully.
- It has to be installed in an area where the access to it is impossible without disassembling the structure of that specific enclosing area of the host appliance.
- The **PPS WAVE** consists of two parts, the **Electronic Control Unit - ECU** - and the **Autotransformer - TRAF0**. None of these parts are serviceable or repairable.



• Beware of hot surfaces. Some parts, such as the transformer, may retain dangerously high temperature for a while, after disconnecting the electrical supply.

• Make sure that dust from borings and grindings does not enter the drive when installing. Electrically conductive dust inside the unit may cause damage or malfunctions.

• Ensure for adequate cooling.

• Do not fasten the device by welding.

1.3. Printed circuit board

WARNING! Ignoring the following instructions may cause damage to the printed circuit board:



• The printed circuit board contains components sensitive to electrostatic discharge. Wear a grounding wrist band when handling the board. Do not touch the board unnecessarily.

Operation

These warnings have to be read and understood by all authorized personnel who operated the ECU.



WARNING! Ignoring the following instructions may cause physical injury or death, or damage to the equipment:

- Before powering the device check the wiring.

2. Mechanical installation

What this chapter contains

This chapter contains packing information and the mechanical installation instructions of the device.

2.1 Packing of the unit

The Electronic Control Unit- *ECU* - of the device is delivered in a cardboard box.
The Autotransformer - *Trafo* - of the device is delivered in a cardboard box.
The type, size and material of the package depends on the frame size of the Autotransformer.

2.2 Before installation

The device must be installed in an upright position (see image below) with allowance for adequate cooling. IP rating is met only when the ECU is installed in a vertical position with the connection tabs at the bottom. This is also important as the ECU also detects ambient temperature as one of its features.

The Control can be mounted using 2 screws M4.
Maximum torque 1,8 Nm.

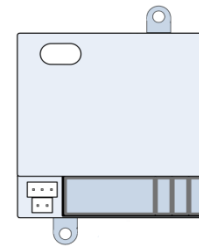

2.3 Dimensions drawings for the ECU (Electronic Control Unit) installation

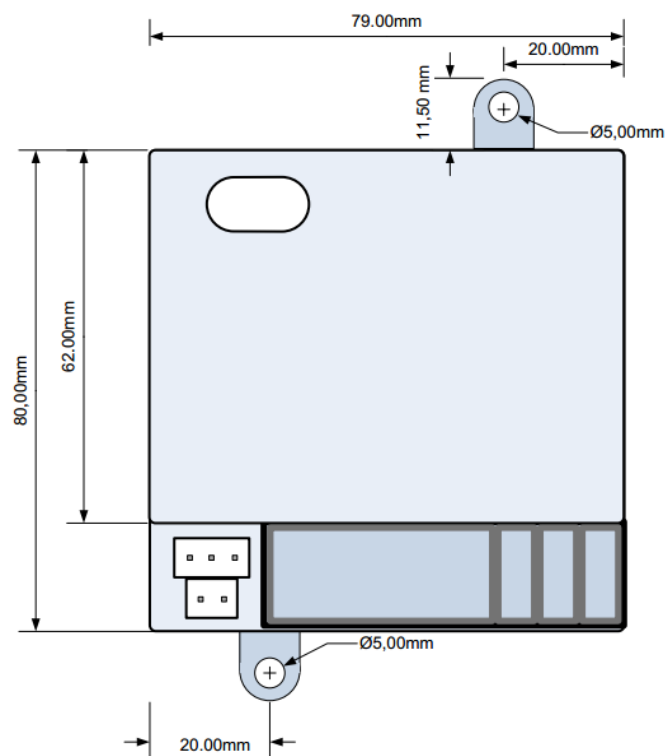

Top View

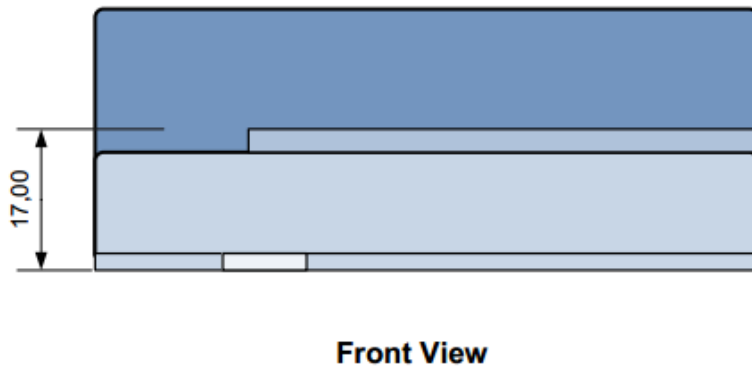
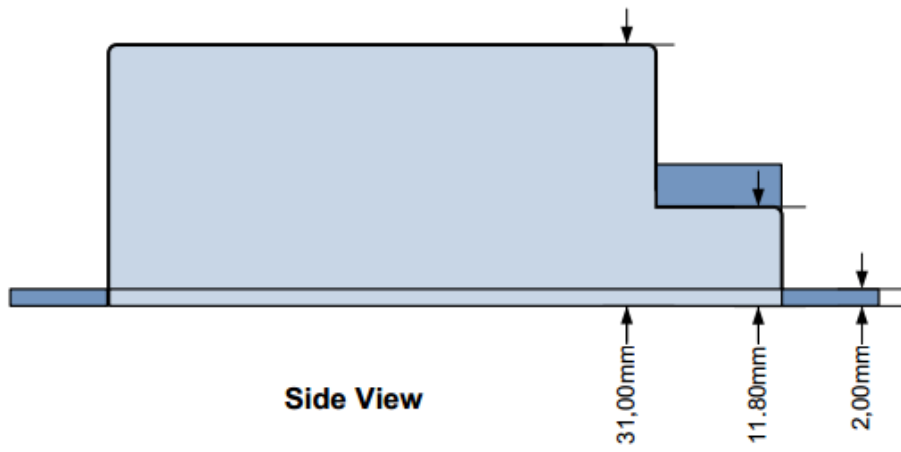

2.4 Dimensional drawings for Autotransformer.

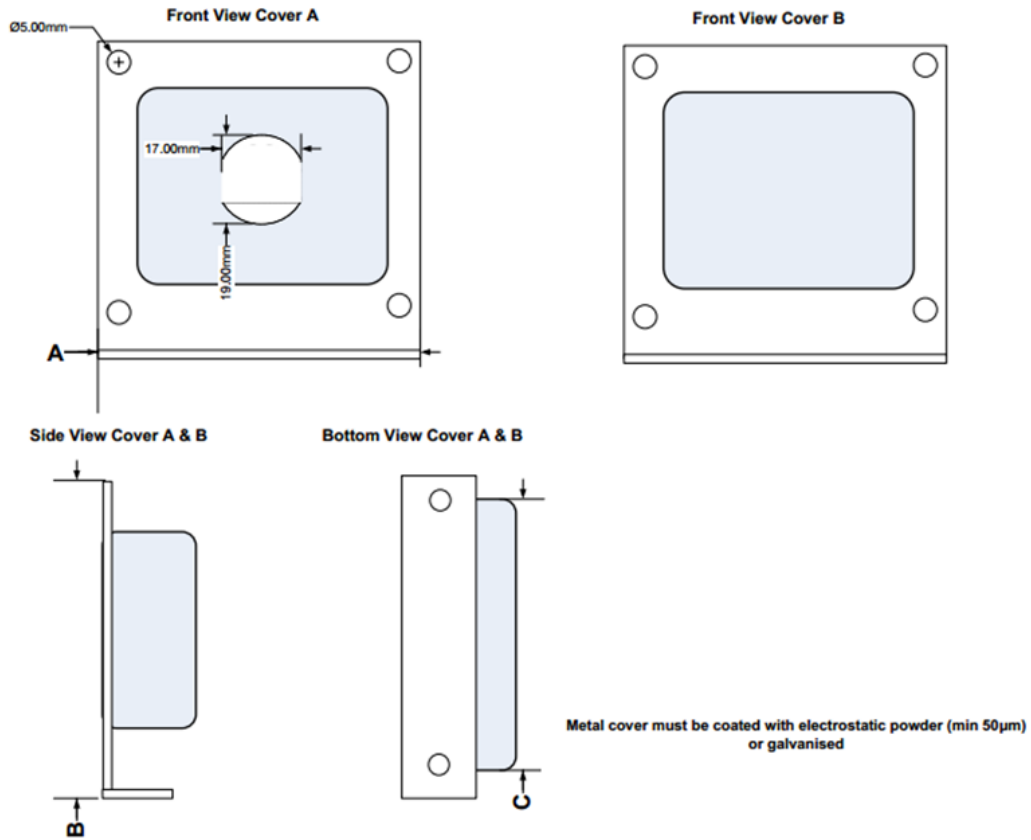

		045	070	090	120
WAVE C	A	85	85	95	-
	B	75	75	85	-
	C	73	73	83	-
WAVE i	A	84	84	96	96
	B	75	75	86	86
	C	73	73	82	82

All dimensions are in mm

3. Electrical installation

What this chapter contains

This chapter describes the electrical installation procedure of the ECU.



WARNING! The procedure described in this chapter may only be carried out by a qualified electrician. Follow the Safety instructions on the first pages of this manual. Ignoring the safety instructions may cause injury or death.

Make sure that the device is disconnected from the mains (input power) during installation.

3.1 Checking the insulation of the installation

Device

Do not make any insulation resistance tests on any part of the PPS WAVE as testing can damage the device. The Autotransformer has been tested for insulation between the main circuit and the chassis at the factory. Moreover, the voltage limiting circuits incorporated in the PPS WAVE will cut down the testing voltage automatically, during an insulation resistance test.

Supply cable

Check the insulation of the supply (input) cable according to local regulations before connecting to the ECU.

PPS WAVE is intended to be used with the protection of a fuse gG, type B, IEC60269-3-1.

Confirm compatibility with connection terminals as well as insulation. The connectors are Fast On terminals 6.3x0.8mm

3.2 Main Supply Connection Diagram

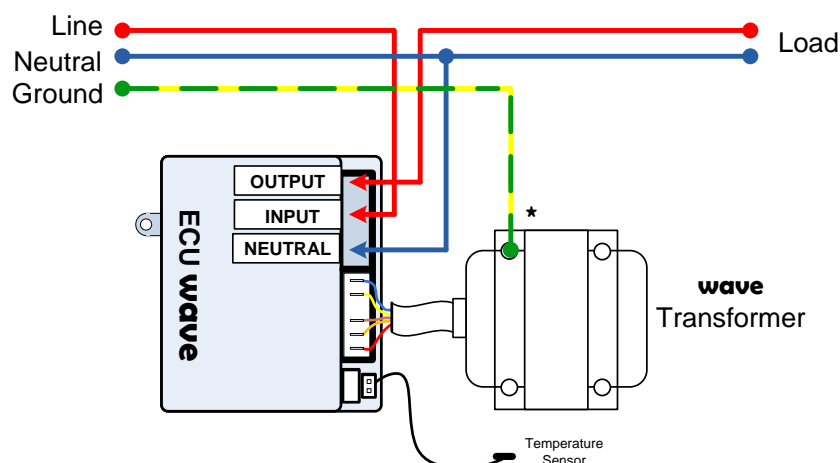

*: Detail of grounding Transformer Enclosure during implementation in the appliance from the installer:

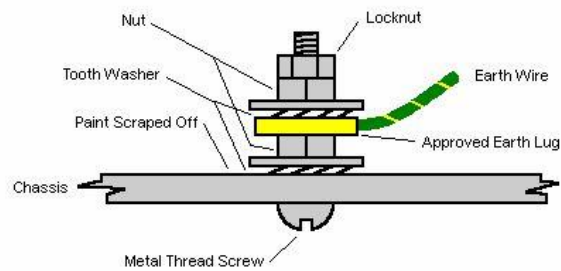

Care should be exercised from the installer to the following:

- PPS WAVE incorporates one terminal intended for the connection of the supply conductors provided by the final equipment (refrigerator).
- The transformer hole and the screw used for Ground conductor connection must not be used for other reason (i.e. mechanical support etc.)
- Earth Conductor must be at least $2,5\text{mm}^2$ of the flexible stranded type. Should the conductor be more than 1 meter in length, earth resistance must be verified to be less than 0.1Ω .
- Earth connection must be realized near the point of the Incoming Protective earth (ground) of the appliance in which the PPS WAVE is incorporated, marked with the symbol:

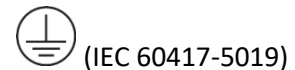

3.3 Connection between ECU and Autotransformer

The PPS WAVE consists of two parts, the Electronic Control Unit - *ECU* - and the Autotransformer - *TRAFO*.

The connection between ECU and Autotransformer has to be done via fast-on terminals. The matching of PCB mounting tabs with Crimp Contacts Receptacles is one by one.

The length of the cable between ECU and Autotransformer vary from 250mm, 550mm, to 1000mm depending on the needs of each customer.



WARNING! Ignoring the following instructions can cause damage to the equipment and/or violate design specifications.

PPS WAVE is made up of non-repairable / refurbishable parts. In an event of a failure of the PPS WAVE, both ECU and TRAFO have to be replaced with new unused units. Part replacement is not advisable.

Before powering the device:

- Be sure that the autotransformer's connector is plugged in to the ECU with the correct order!
- Confirm the correct fitting of the terminals to ensure IP rating of the connections.

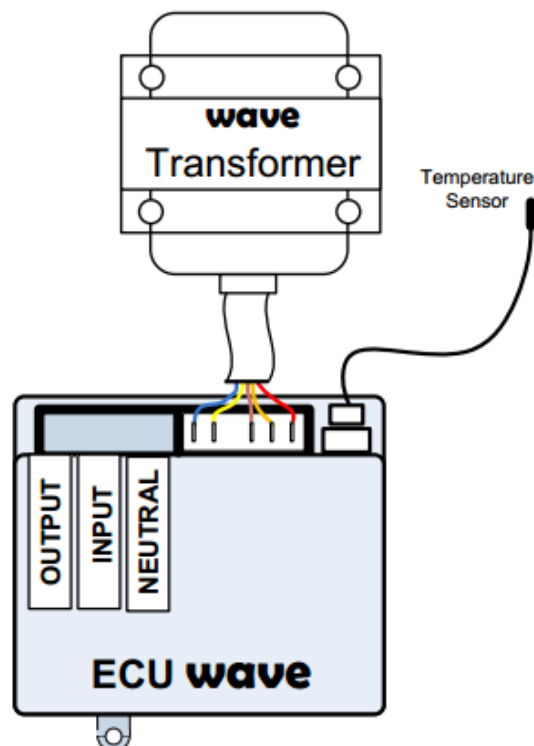

Further Information

Support: rnd@thyratron.gr

Sales: sales@thyratron.gr

Site: www.thyratron.gr

Follow us at [linked in](#), [Facebook](#)

Address: Kydonies Vasiliko, Erymanthos, Achaia, GR25008, HELLAS

Tel: +30 26940 61868 Fax: +30 26940 62001